

Nikolatesla switch

Downdraft induction cooktop



Learn
more

MEASUREMENTS

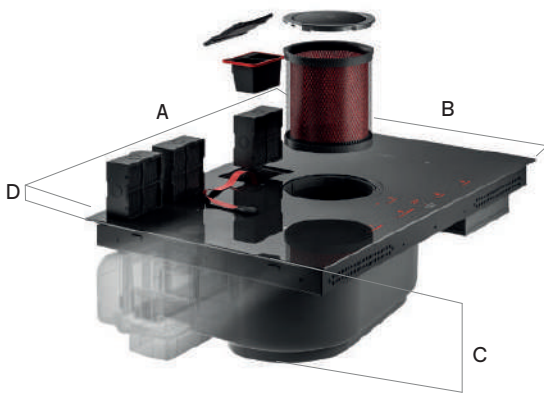

*The product images shown are for illustration purposes only and may not be an exact representation of the product.

ENS436BL	
A	36" (91.54 cm)
B	20 1/4" (56.4 cm)
C	8 1/4" (25.9 cm)
D	3/8" (6.4 cm)

DESCRIPTION

Extremely clean lines give life to a truly exclusive appliance, NikolaTesla Switch, a concentrate of design and technology through which Elica has revolutionized the daily cooking experience.

A return to the origins with a simple induction cooktop, featuring continuous surfaces and a display that becomes completely invisible in stand-by mode. The extraction area is cleverly hidden by a black glass and steel disk, characterizing the product without clashing with the other elements

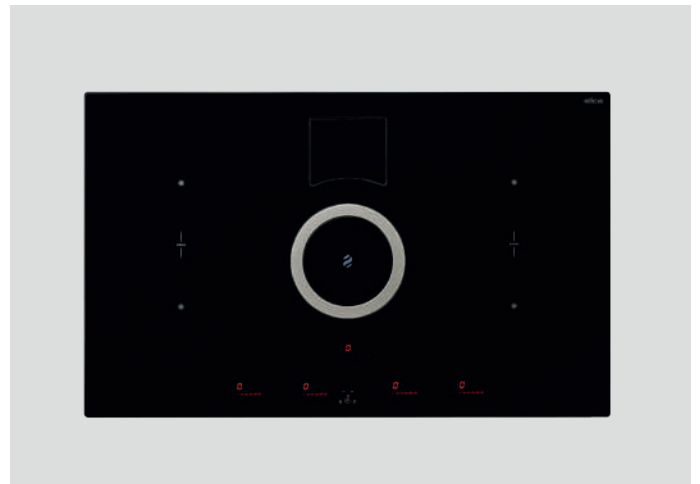

FEATURES

- Timer
- Child lock
- Pot self-detection
- Easy to maintain
- Stop and go
- Delay switch off
- Temperature manager
- Long life filter ++
- Bridge zones
- Total integration
- Airmatic
- Touch controls



GENERAL PROPERTIES

Width	36"
Model	ENS436BL
Dimensions	36"W x 20 1/4"D x 8 1/4"H
Electrical	208-240V-60Hz 440 Watts at 3.3 Amps 240V - 7.8kW at 32.5 Amps 208V - 7.1kW at 34.1 Amps
Finish	Tempered, ultra deep black ceramic glass
Controls	Electronic glass touch & slide w/red illumination
Installation type	Ducted out or recirculating w/kit
Ventilation	4 speed (3 speed + boost)
Blower Type (Internal) ¹	400 CFM
Noise (Min-max sones) ¹	1.5-6.8 Sones
Grease filter	6 layer, black anodized aluminum mesh grease filter
Cooking zones	4 Cooking Zones 4(2.1-3.7 kW) - 7.1" x 7.9"
Heating type	Induction
Heating level	10 levels (9 + boost, see details in chart below)

WARRANTY:² Two (2) Years Parts & In-Home Labor. Earn an additional One (1) Year of Parts & In-Home Labor by registering on elica.com

Cooking level	Power (W)
Low	53 W
Level 1	63 W
Level 2	105 W
Level 3	168 W
Level 4	252 W
Level 5	378 W
Level 6	588 W
Level 7	882 W
Level 8	1344 W
Level 9	2100 W
Booster	3700 W

Glass specifications

Material	Glass ceramic cooking panel
Appearance	Deep-black color
Thickness	4 mm
Color in reflexion	Black
Color in transmission	Amber
Surface structure	Though crystal smooth scratch & stain-resistant

SELF RIMMING INSTALLATION

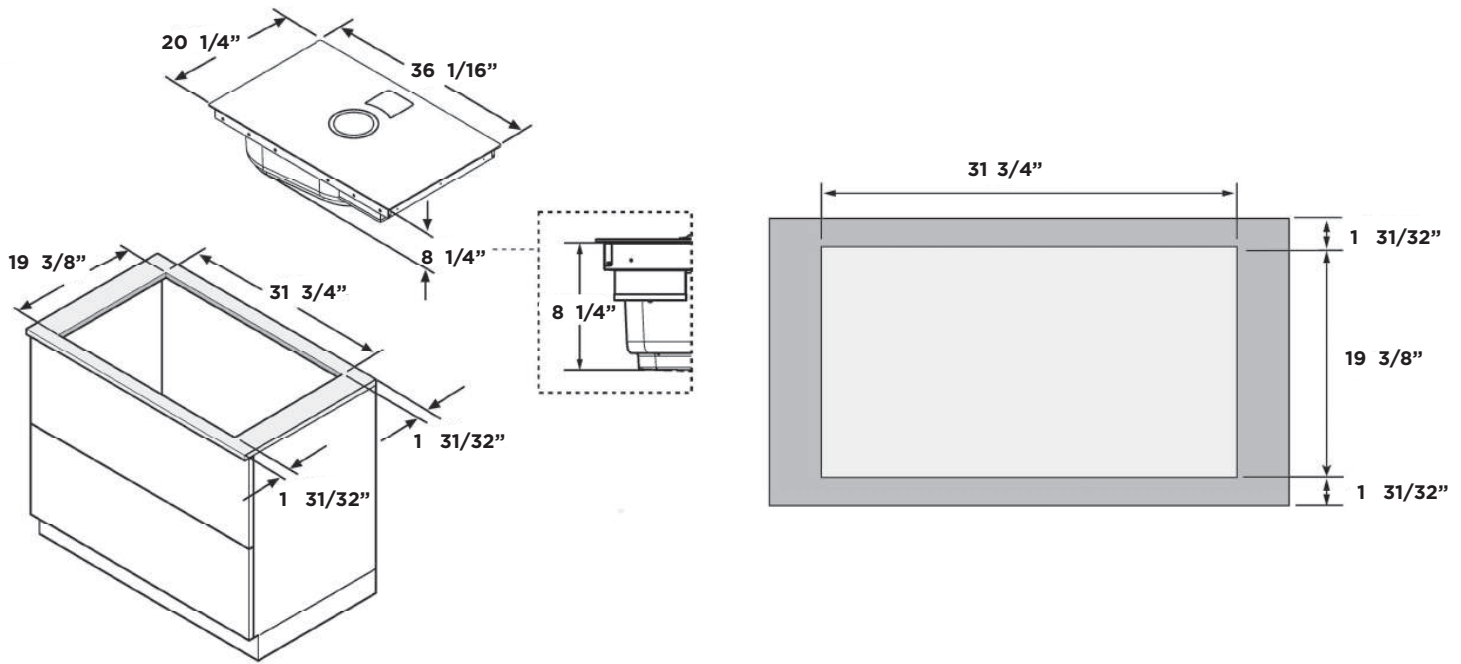

FLUSH MOUNTED INSTALLATION

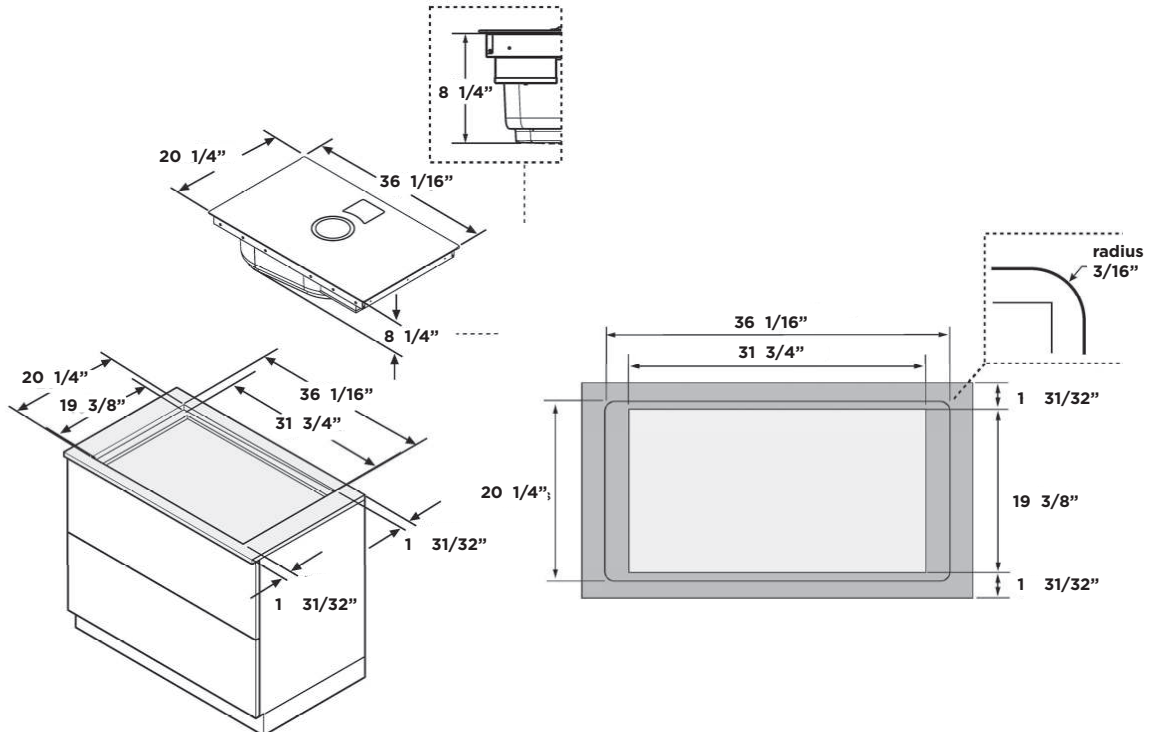

The product images shown are for illustration purposes only and may not be an exact representation of the product.
¹ CFM and Noise data indicate the performance of the hood blower tested according to international standards. For AHAM Certified Ratings, established in accordance with California Title 24 Standardized test procedure, please refer to AHAM Certified Product Directory. Electric Ratings are declared according to UL.
² For valid warranty extension, register within 3 months from purchase. For USA & Canada Users Only.