

Dolomite 30''

Specification sheet

Built-In / Panel Ready Refrigeration Column

MEASUREMENTS

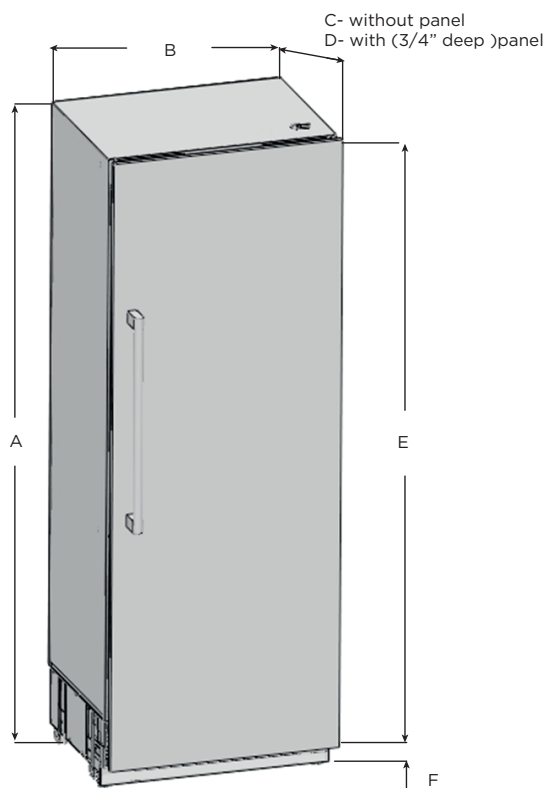

DESCRIPTION

Our 30" Built-In Refrigeration Column boasting an impressive 16.6 CuFt Capacity. This isn't just an appliance; it's a statement of modern living with ample storage space, customizable temperature control, and perfect preservation for your food.

Immerse yourself in seamless integration with Panel Ready Capabilities and unique 3D adjustment for flawless flush installation. Redefine your kitchen experience with a touch of elegance and practicality, all while enjoying the flexibility to configure your kitchen with different design layouts.



FEATURES

- Articulated hinge
- Quiet operation
- Panel ready
- Eco-mode
- Smart storage

EC30SRN16IPR EC30SRN16IPR-L

	EC30SRN16IPR	EC30SRN16IPR-L
A	83 ⁹ / ₁₆ " (212.3 cm)	
B	29 ³ / ₄ " (75.6 cm)	
C	23 ⁵ / ₁₆ " (59.2 cm)	
D	24 ¹ / ₄ " (61.6 cm)	
E	79 ¹⁵ / ₁₆ " (203 cm)	
F	3 ⁵ / ₈ " (9.2 cm)	

GENERAL PROPERTIES

Width	30" Unit
Model	EC30SRN16IPR (Right Side Handle) EC30SRN16IPR-L (Left Side Handle)
Dimensions	29 1/16" W x 23 5/16" D x 83 9/16" H
Cut Out Dimensions	30" W x 25" D x 84" H
Weight	289 lbs (Net) - 320 lbs (Packaged)
Installation type	Built-In, Bottom Mount
Door Finish	Panel ready/Stainless Steel Kit
Reversible Door	Field Reversible
Interior Finish	White plastic liner
Hinge Design	Articulating 90° opening flush hinge
Refrigerant type	R600A
Compressor	Donper
Total Capacity	16 cuft
Noise	Ultra Quiet 43 db(A)
Lighting	LED 6500K 300 lumens, 100 lumen for Freezer.
Controls	Electronic Soft-Touch Digital Black Glass display

ELECTRIC DATA

Electric	115V/60 Hz & 220-240 V/ 50-60Hz
Plug Type	NEMA 5-15 P plug
Power Cord Length	7.5 feet
Energy consumption	325 kw/year

REFRIGERATION ZONE

Fridge Capacity	16.6 cuft
Temperature range	+35°F (2°C) to 46°F (8°C) Chiller drawer 30°F (-1°C) to 41°F(5°C)
Shelving	1 stationary + 3 Height adjustable cantilever Spill-Proof Glass shelves
Drawers	3 Humidity control Drawer + 1 Chiller Adjustable Temp Drawer
Door Storage	1 Gallon Sized Bin + 2 Height adjustable Bins
Water Dispenser	Filtered Water (1. 15 - 75 PSI water pressure)

OTHER FEATURES

Sabbath & Holiday Mode
ECO Mode
Soft close crisper & pantry drawers
Ultra Quiet operation
True Flush Install - 3D door adjustment
Cool Day LED interior light side walls & ceiling

KITS

30" Stainless Steel Panel	EPNKC30SS (3/4" deep)
Pro Handle Stainless Steel	EPHKCSS
Tubular Handle Stainless Steel	ETHKCSS
Column Joining Kit	ECJKCXX

WARRANTY:¹ Two (2) Years Parts & In-Home Labor. Earn an additional One (1) Year of Parts & In-Home Labor by registering on elica.com



The product images shown are for illustration purposes only and may not be an exact representation of the product.
¹ For valid warranty extension, register within 3 months from purchase. For USA & Canada Users Only.